

3125 (RH-61) Schematics and Layouts

Top-Level Diagram

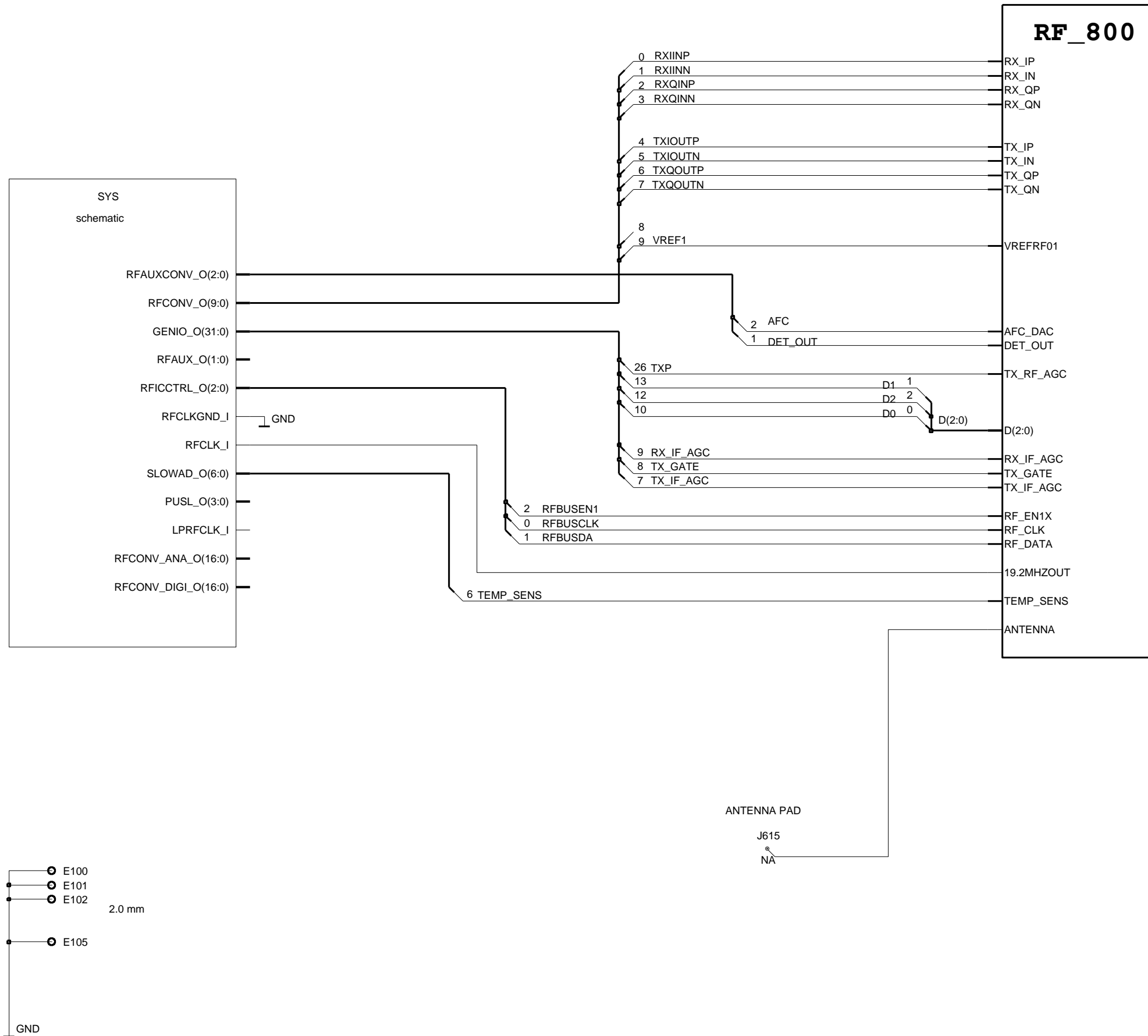

RF Top Level

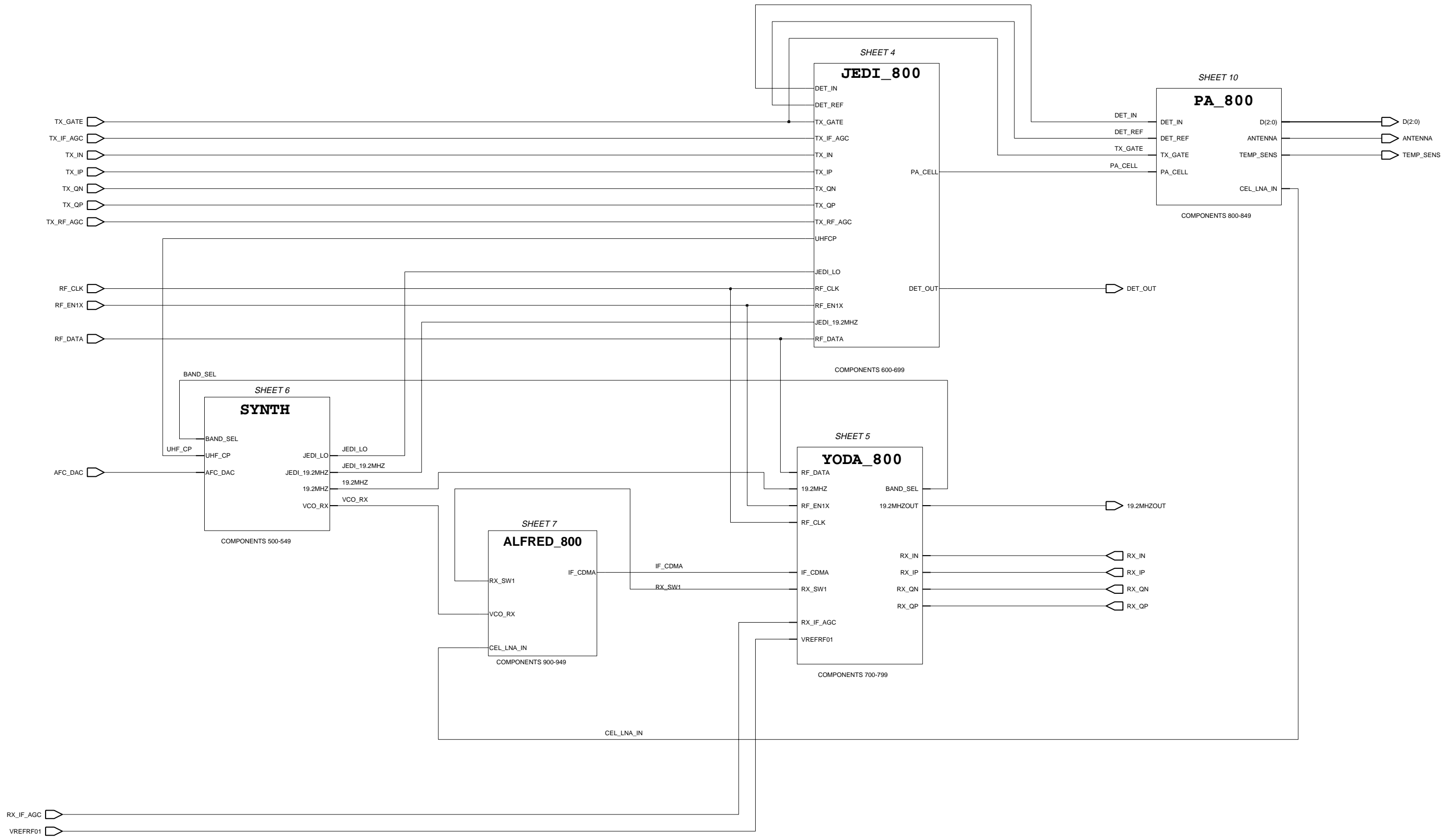

PA

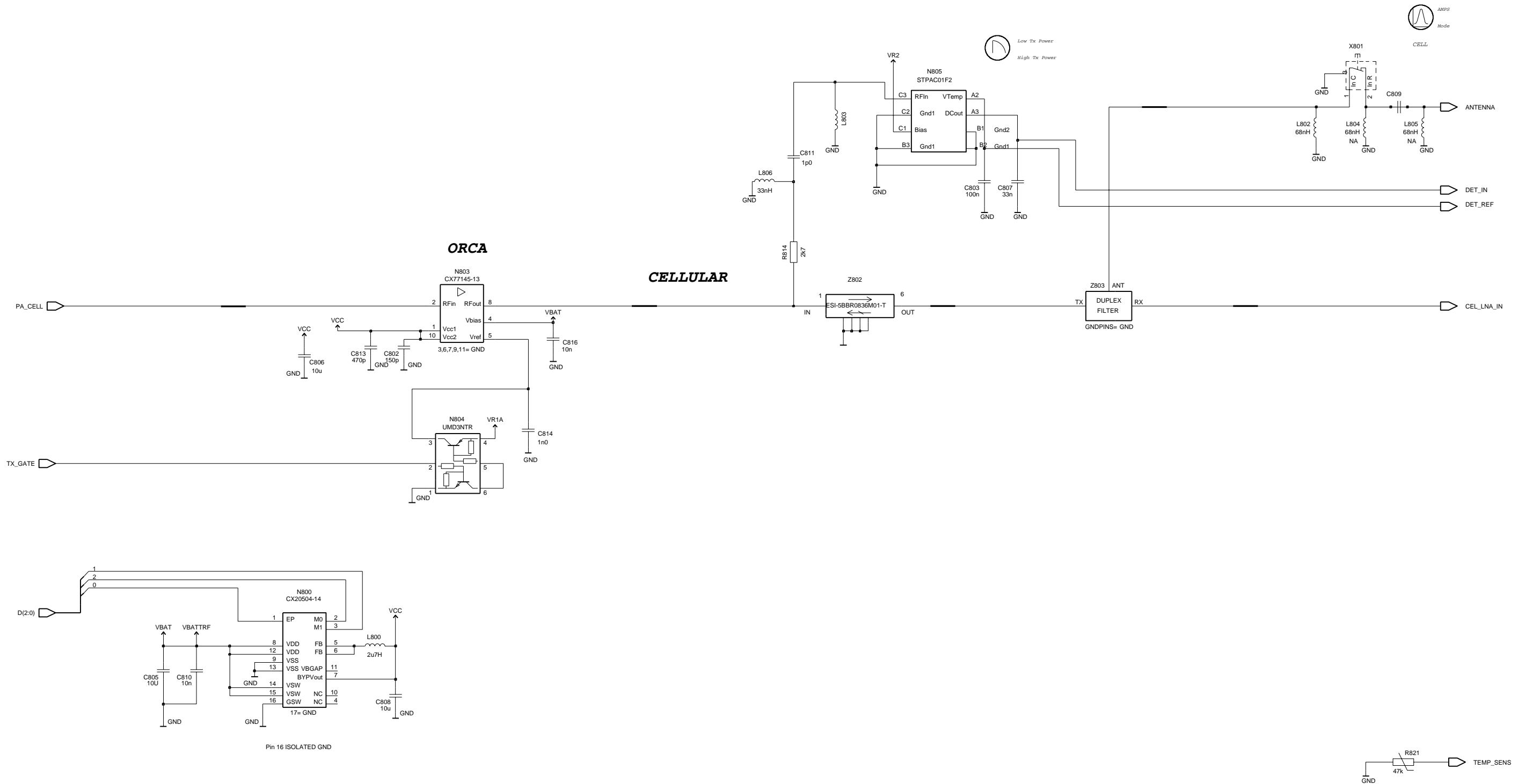

Jedi

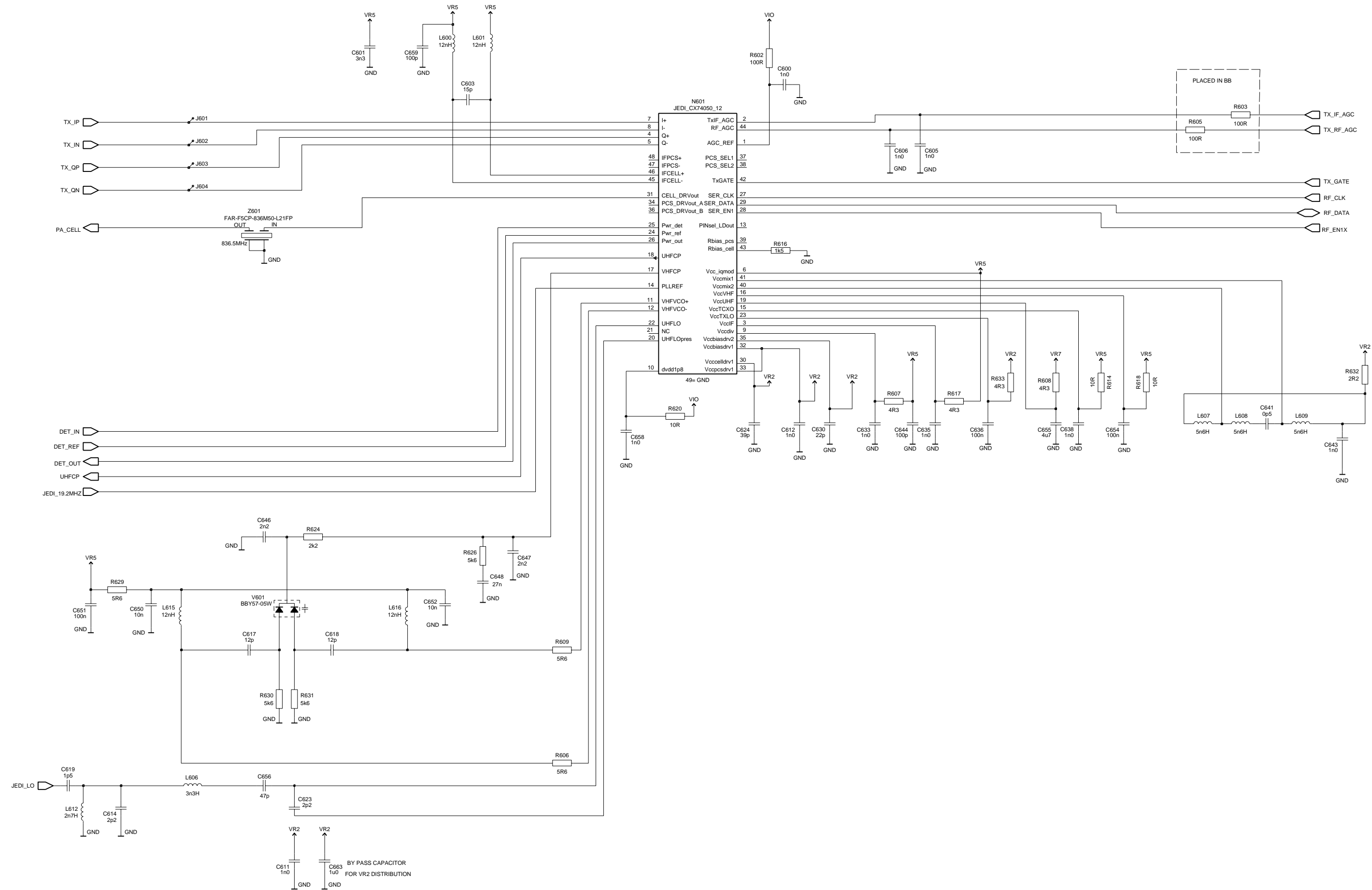

Yoda

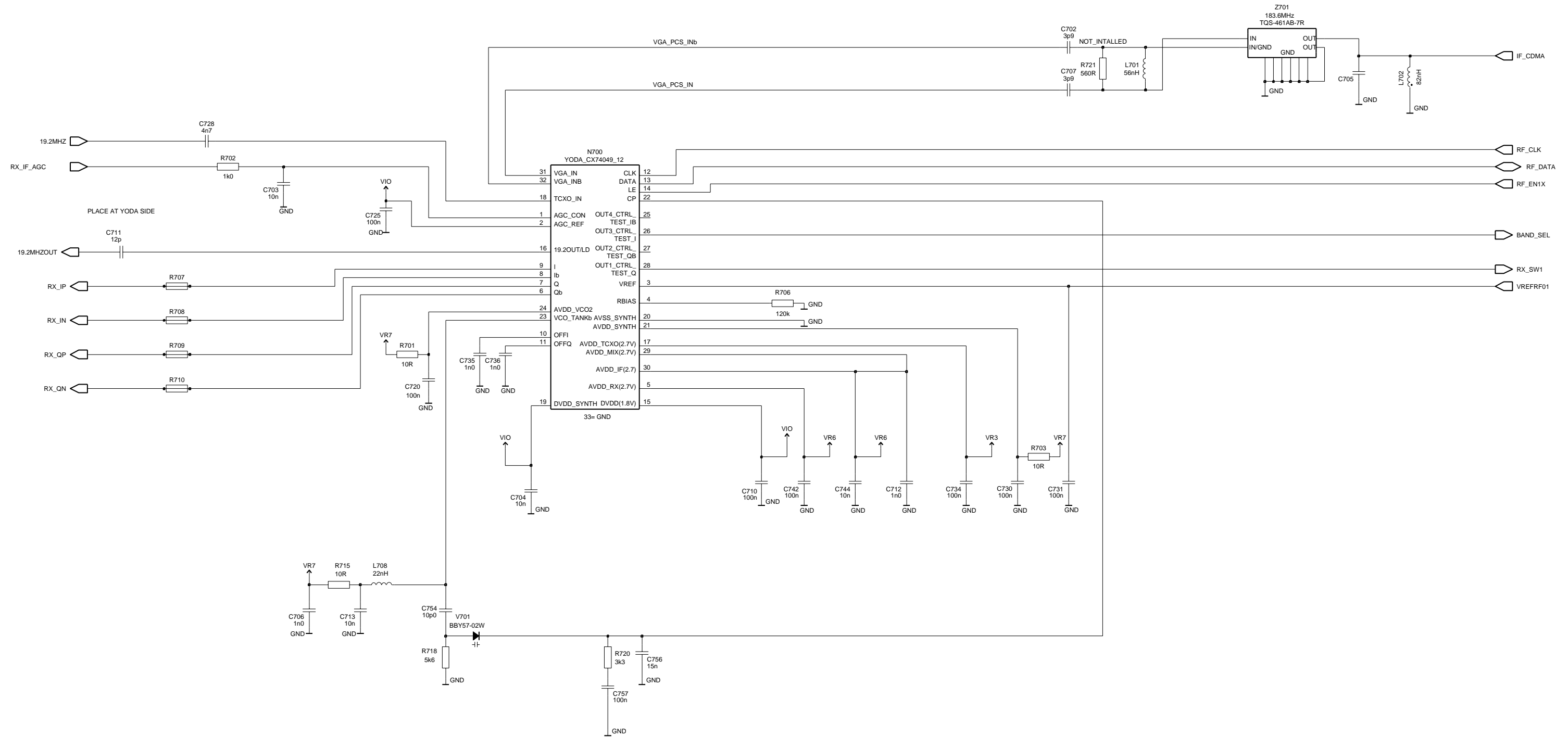

Synthesizer

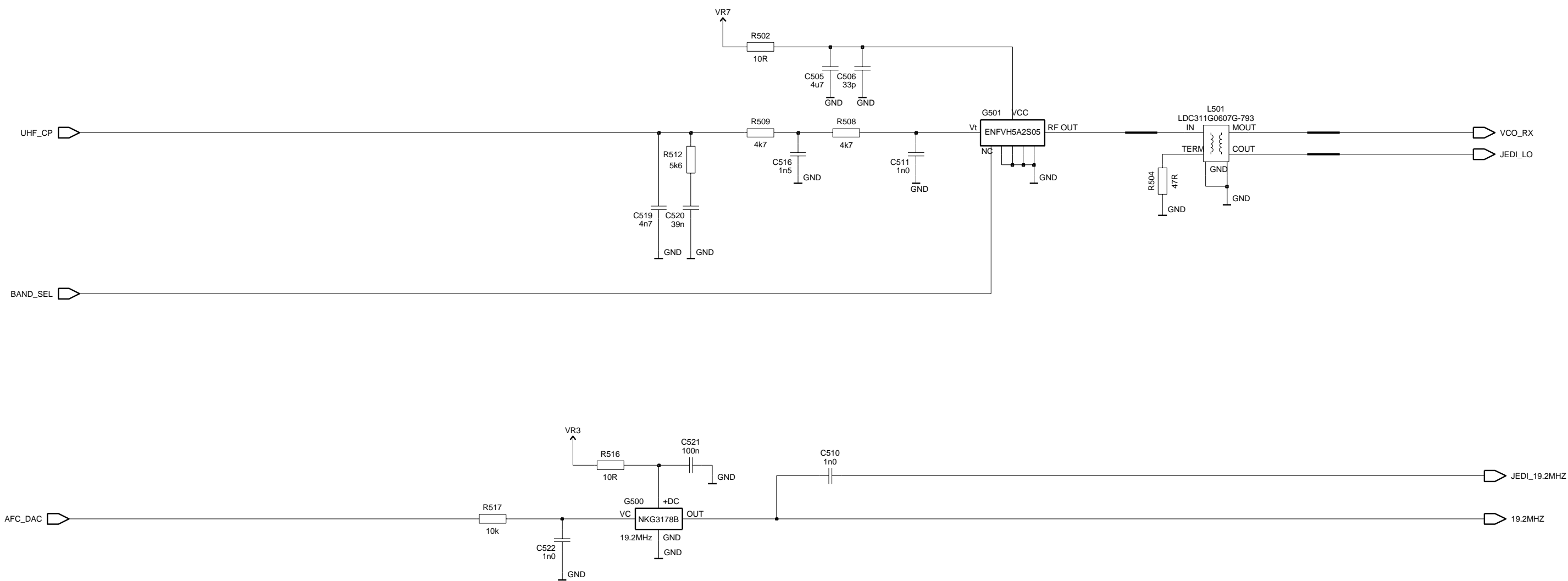

Alfred

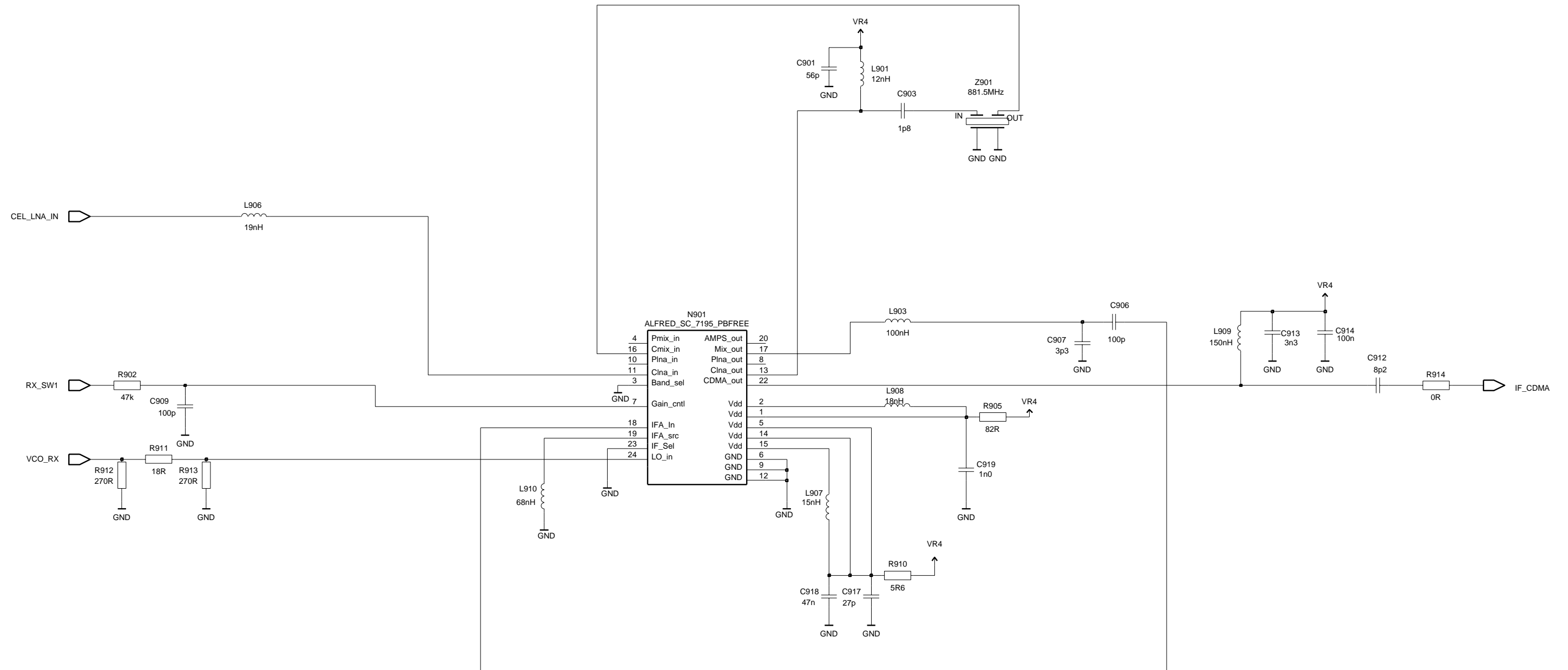

Baseband Top Level

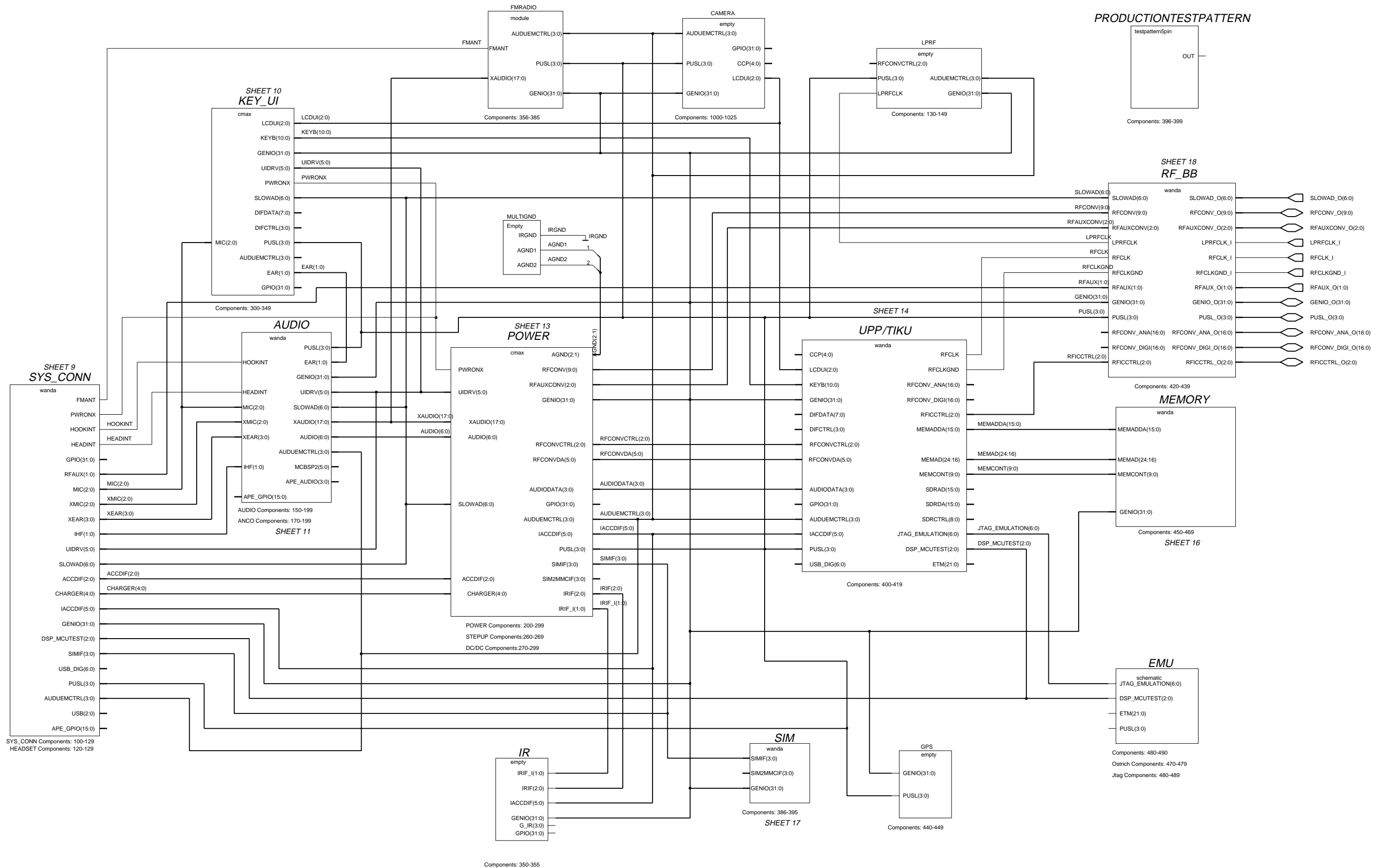



System Connector

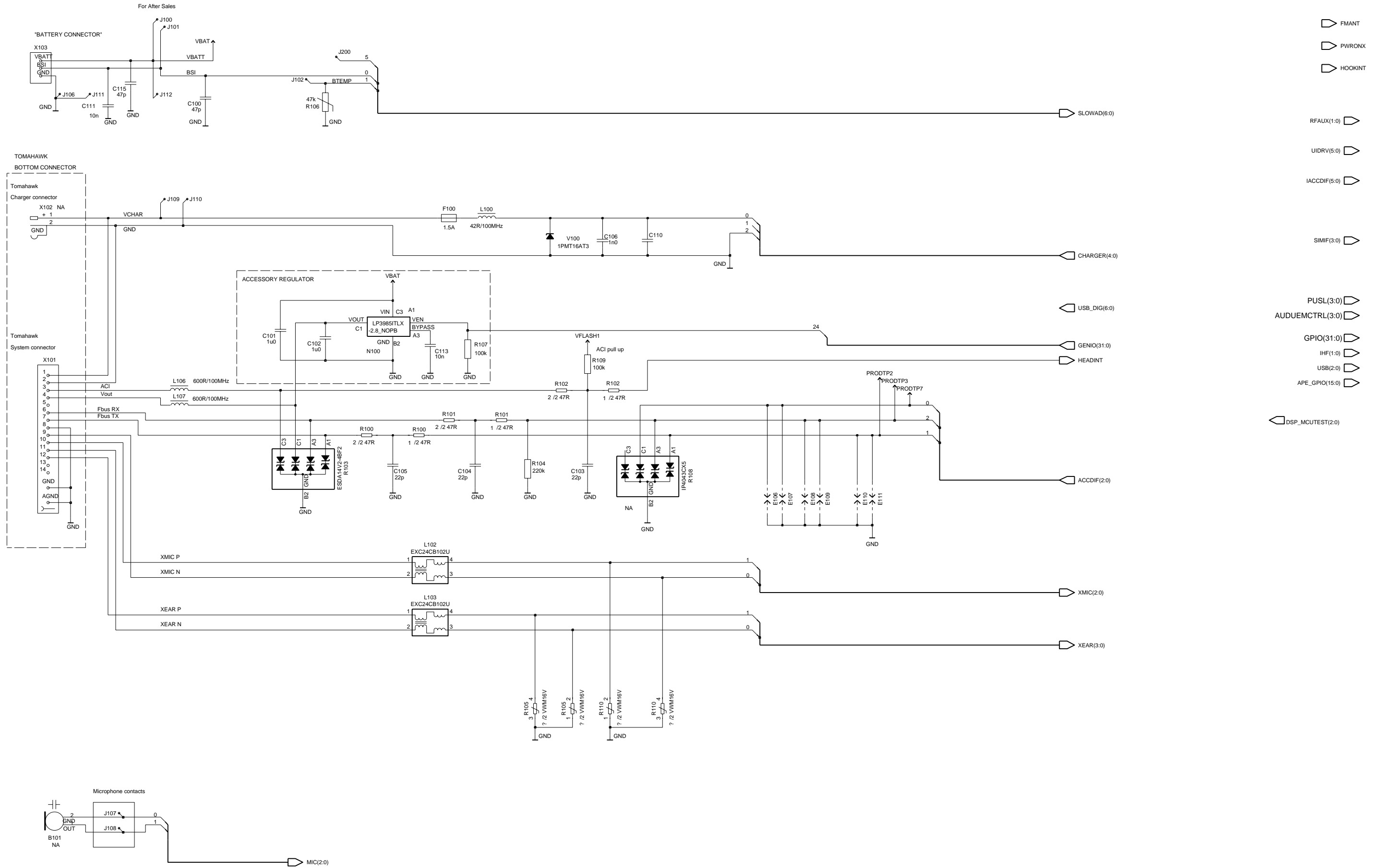

User Interface

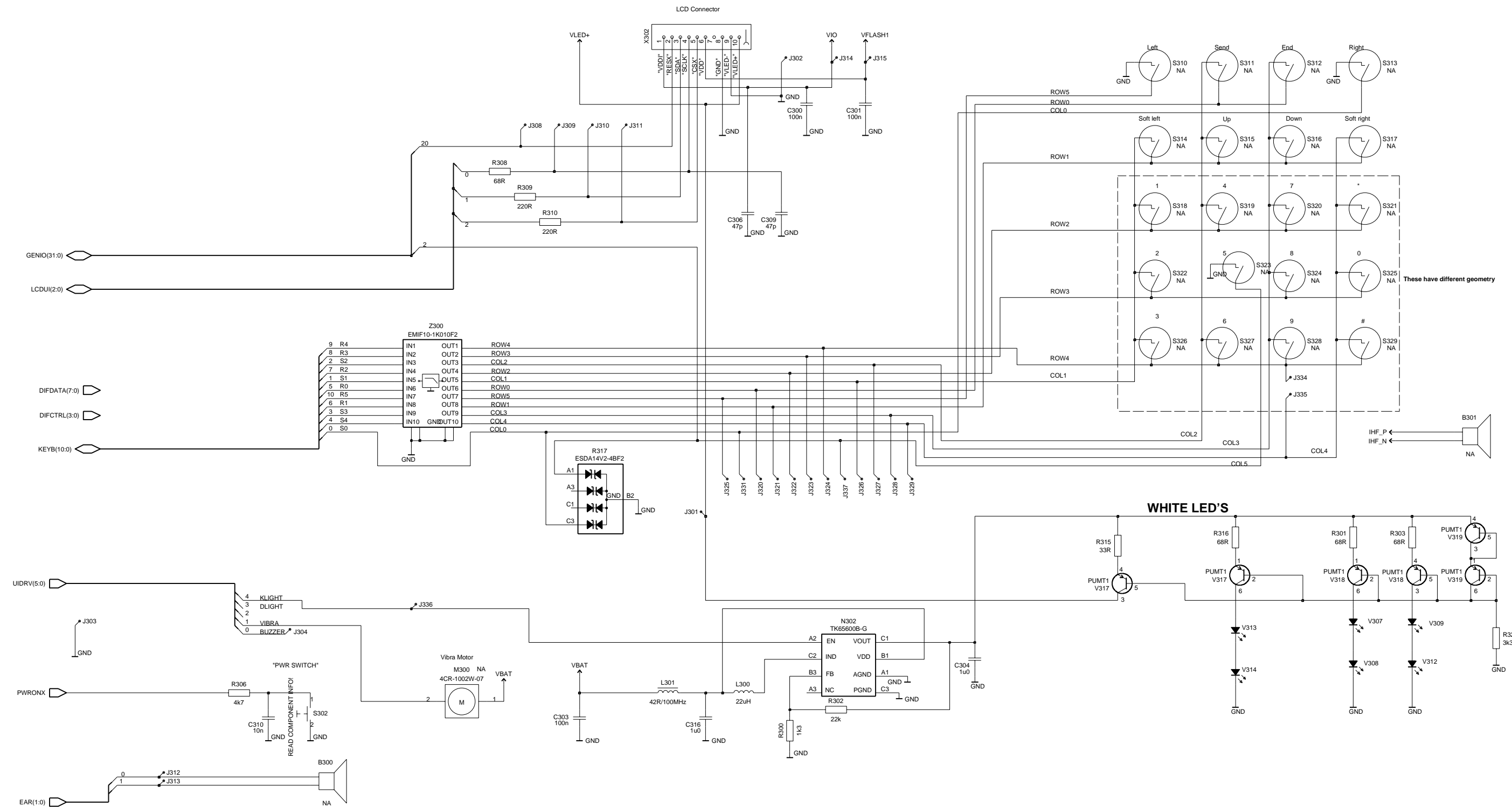
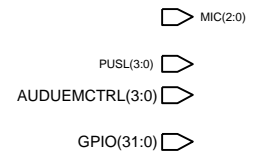
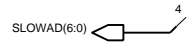

Audio

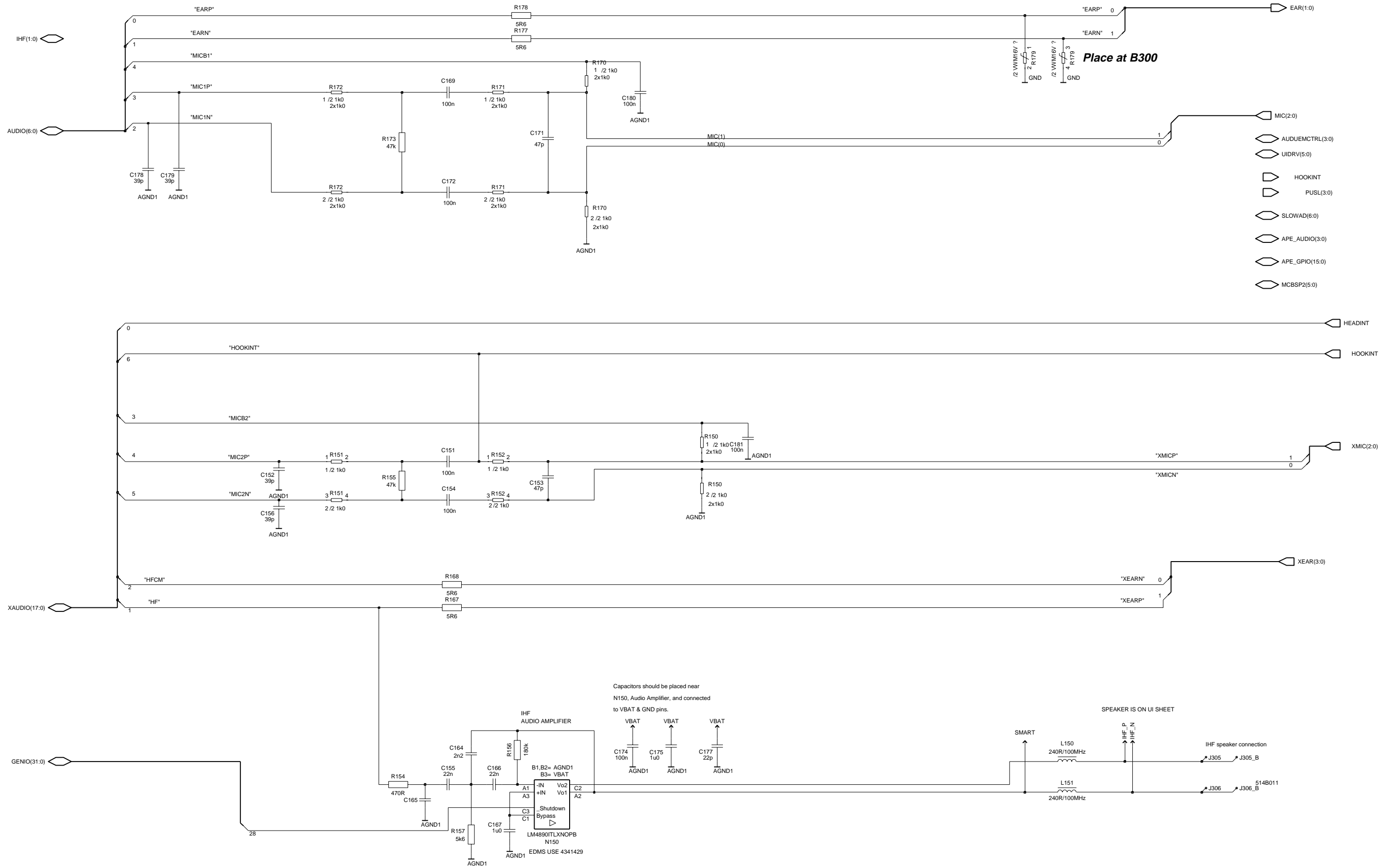

UEM

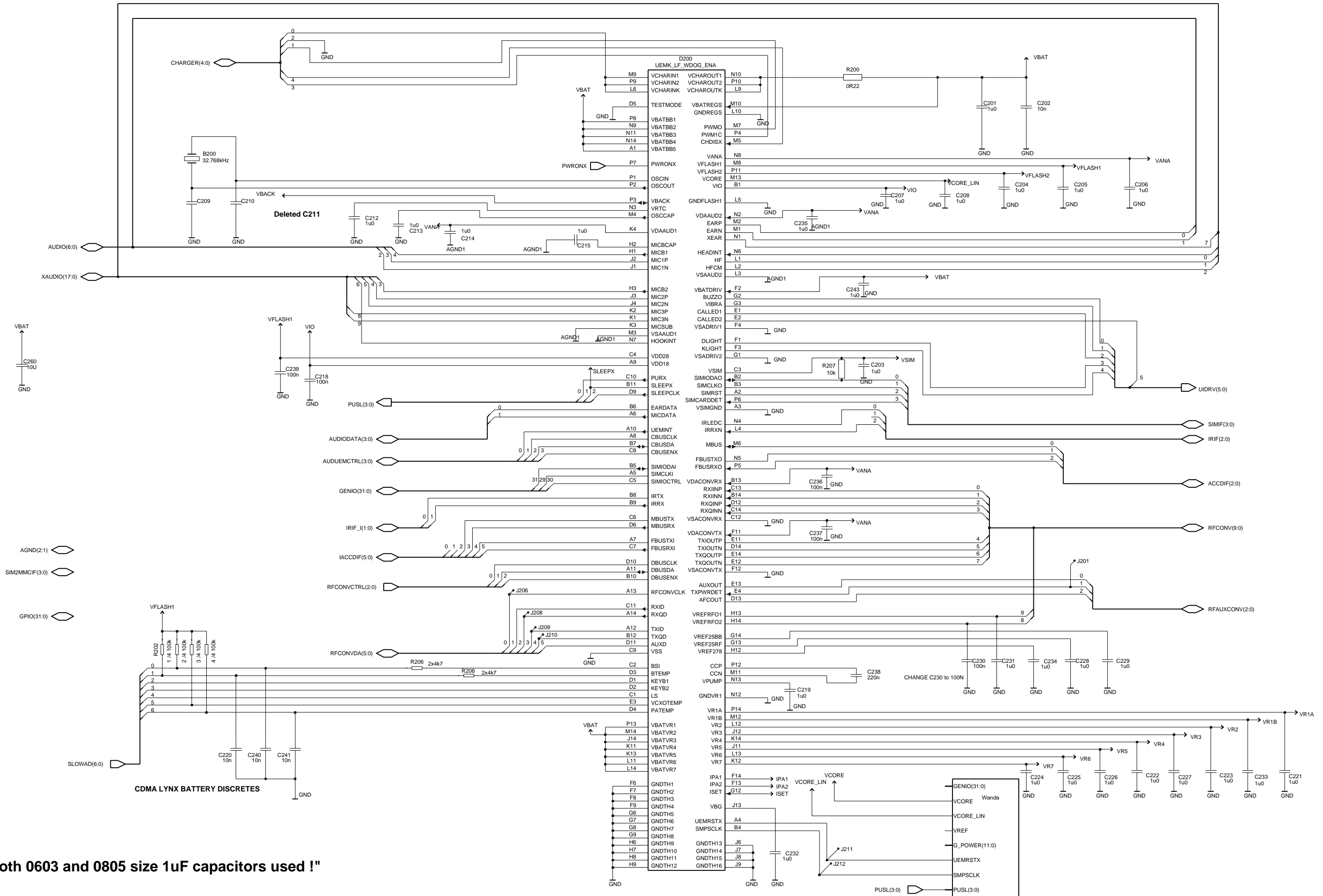

"Both 0603 and 0805 size 1uF capacitors used !"

DC/DC Converter

VCORE LIN

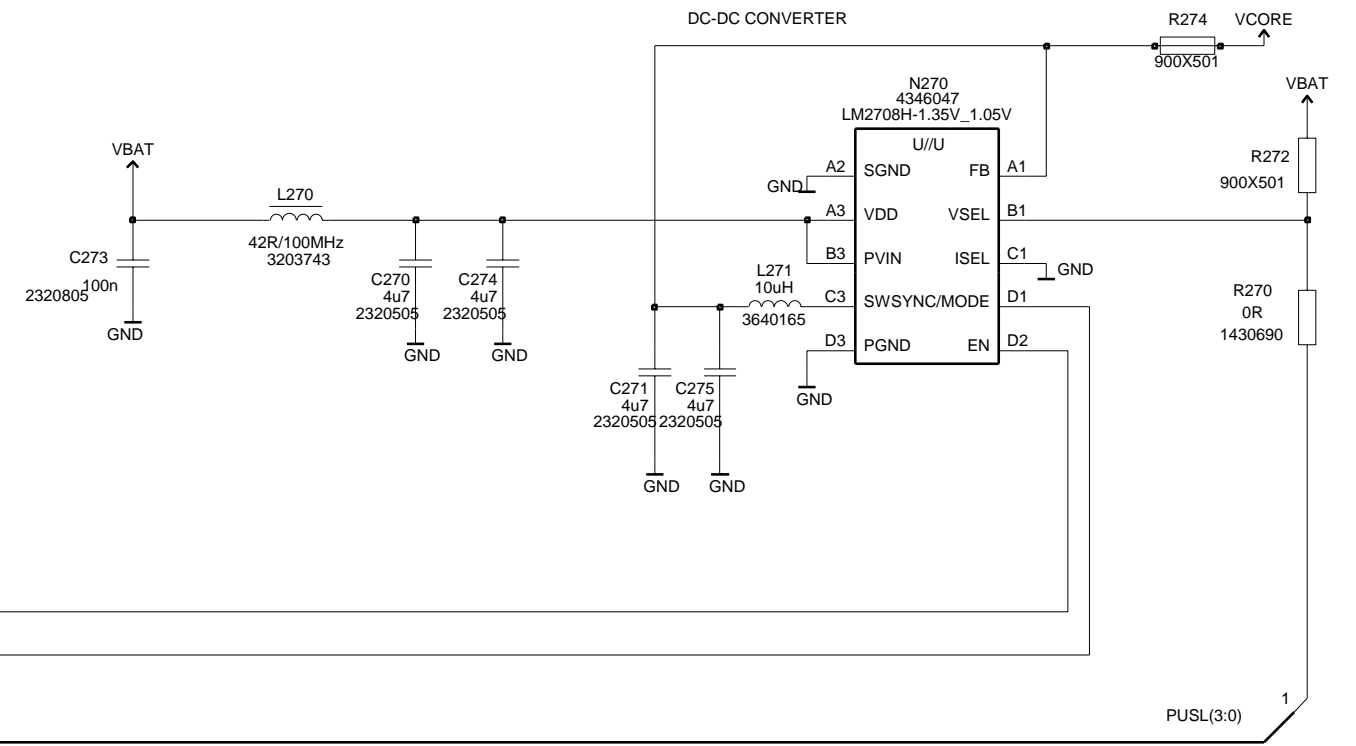

UPP

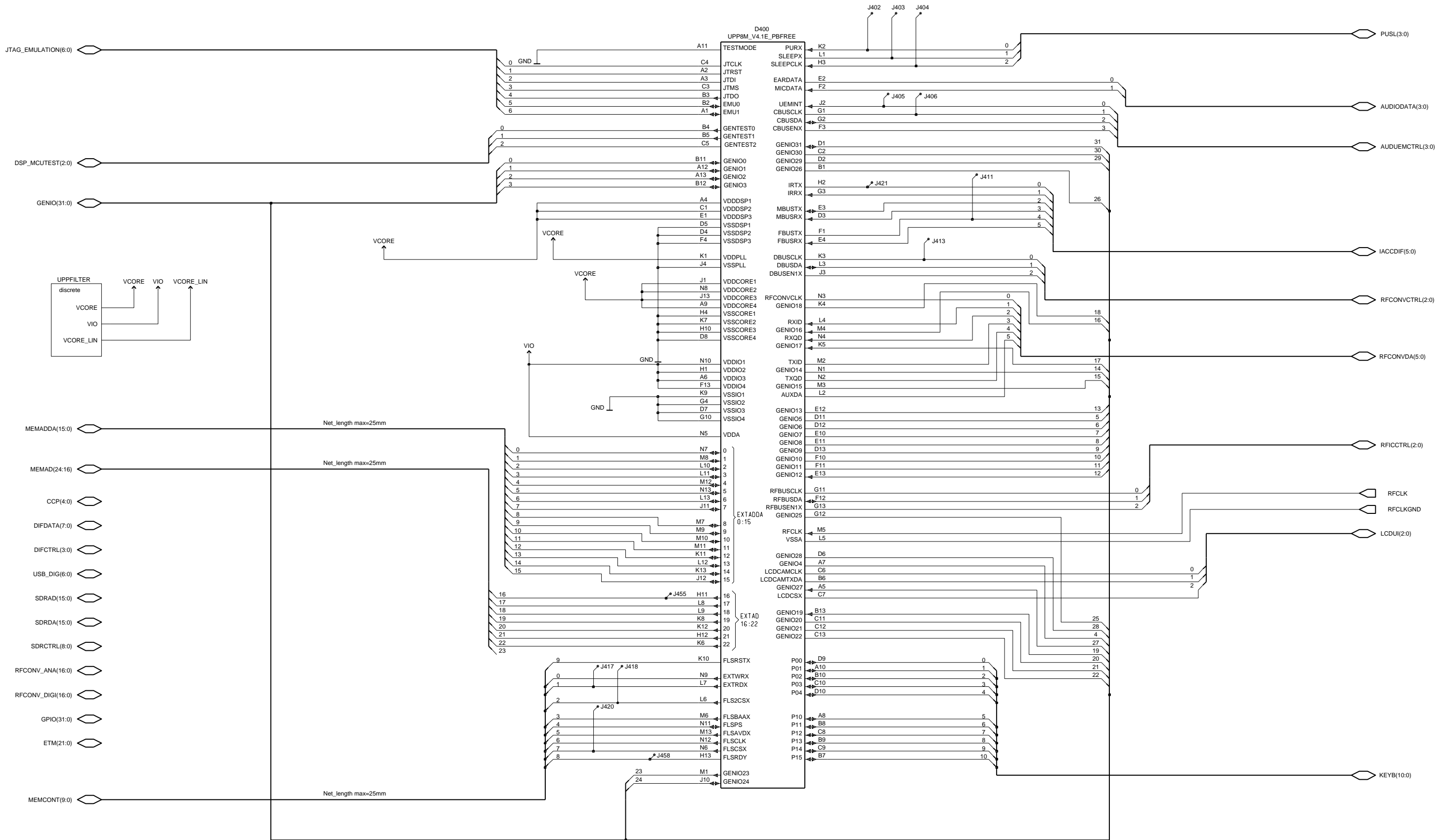

UPP Filter

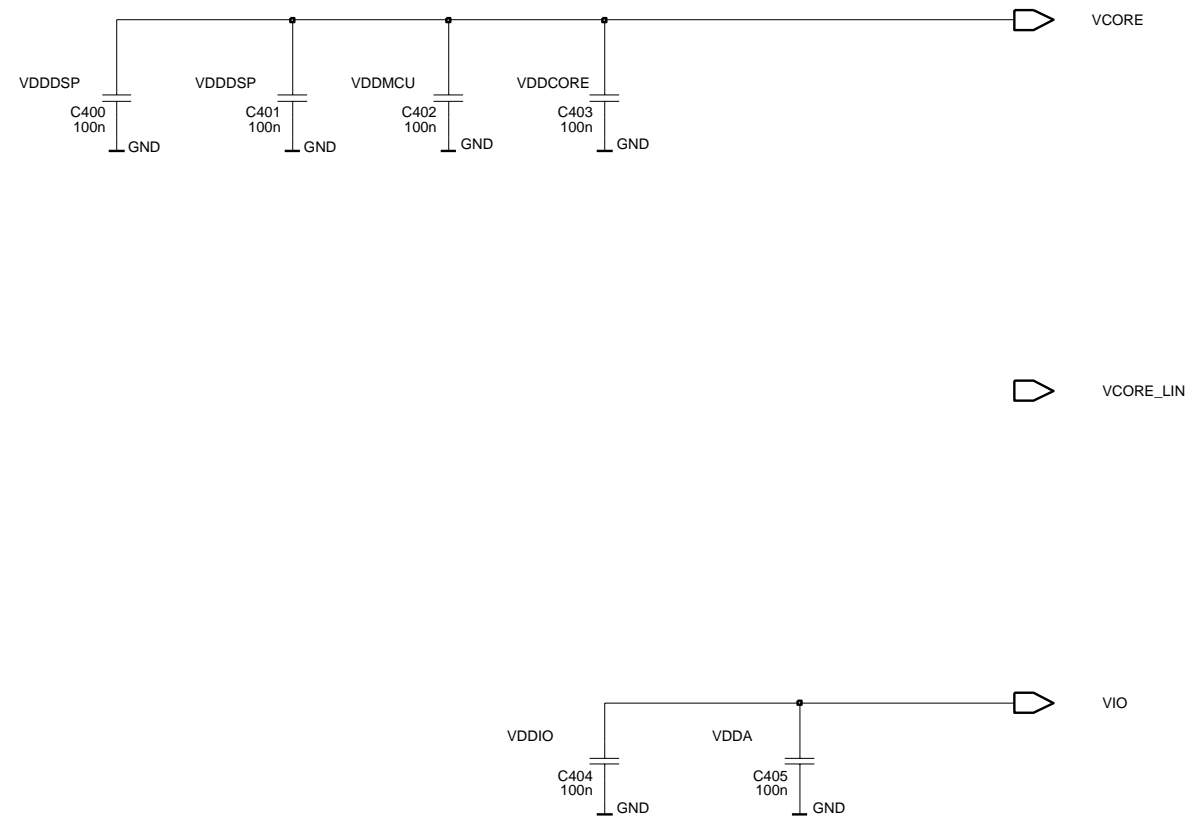

RUIM Reader

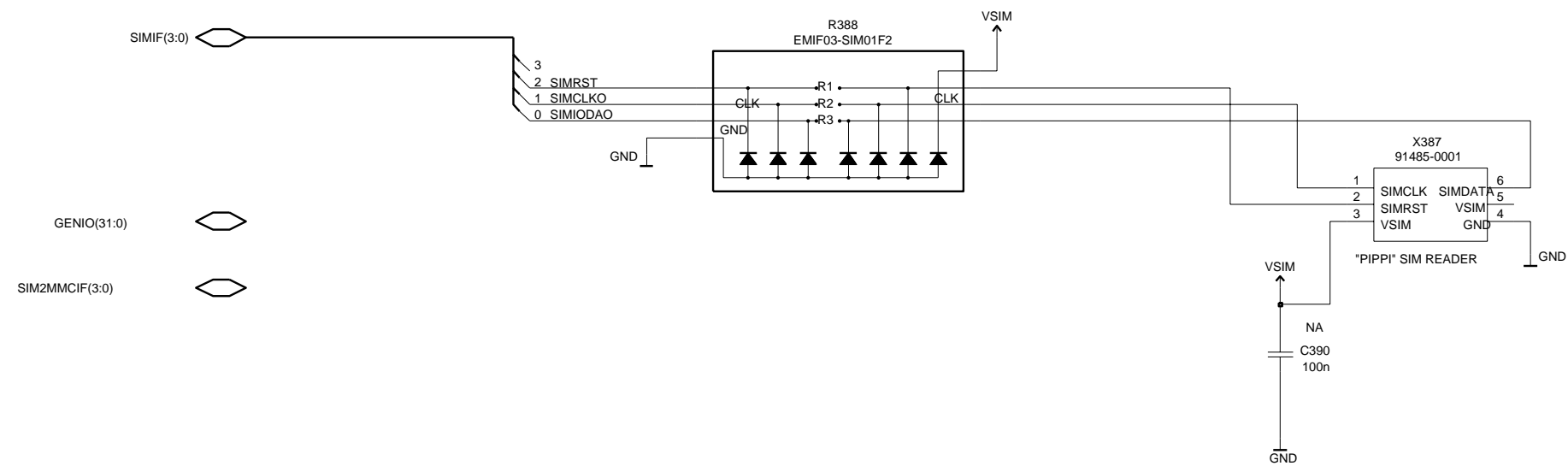

Combo Memory 128+8 Mbit

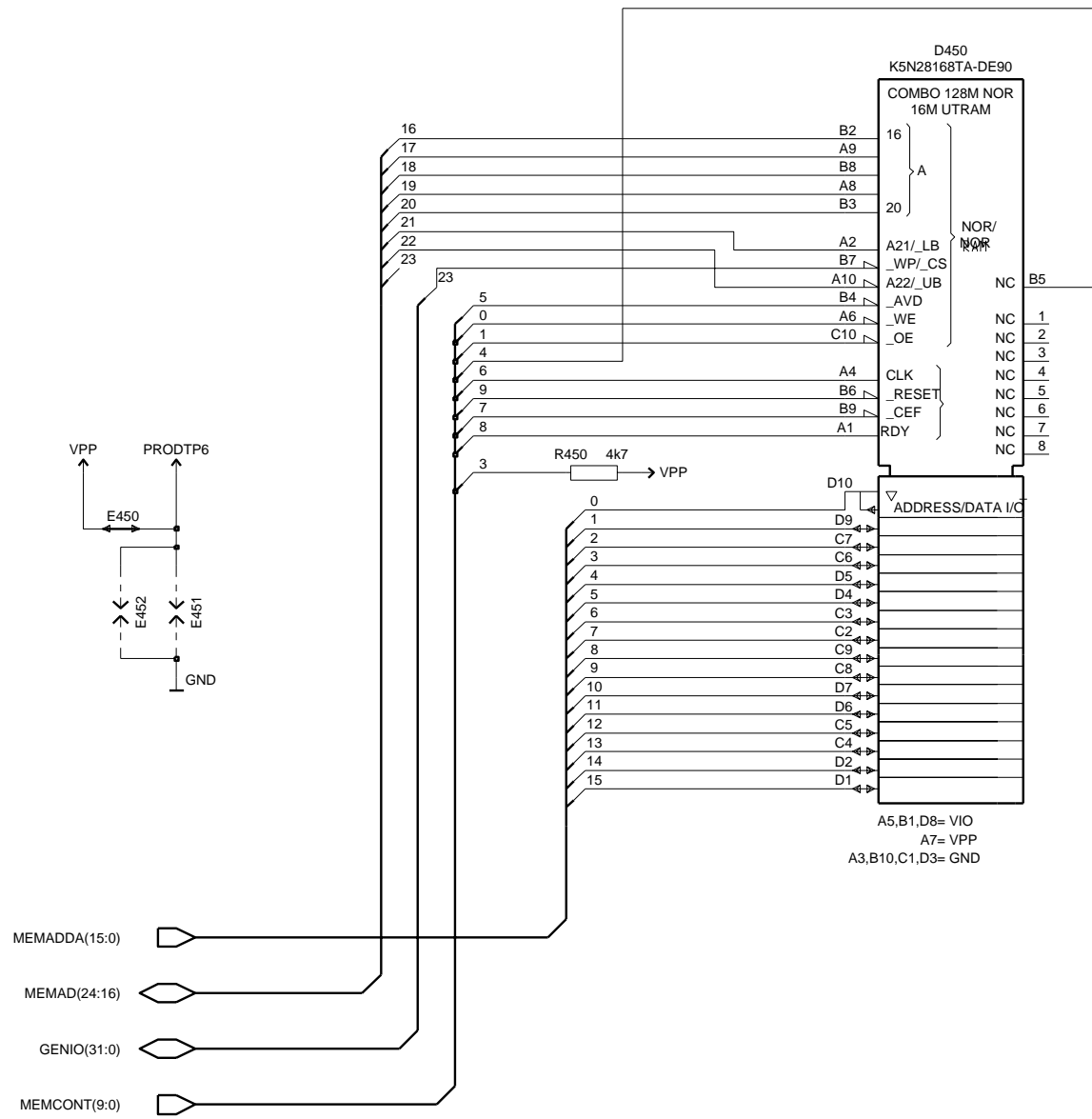
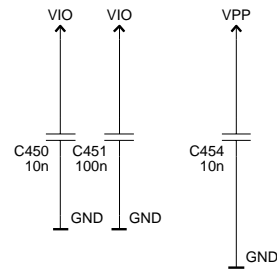



BB-RF Interface

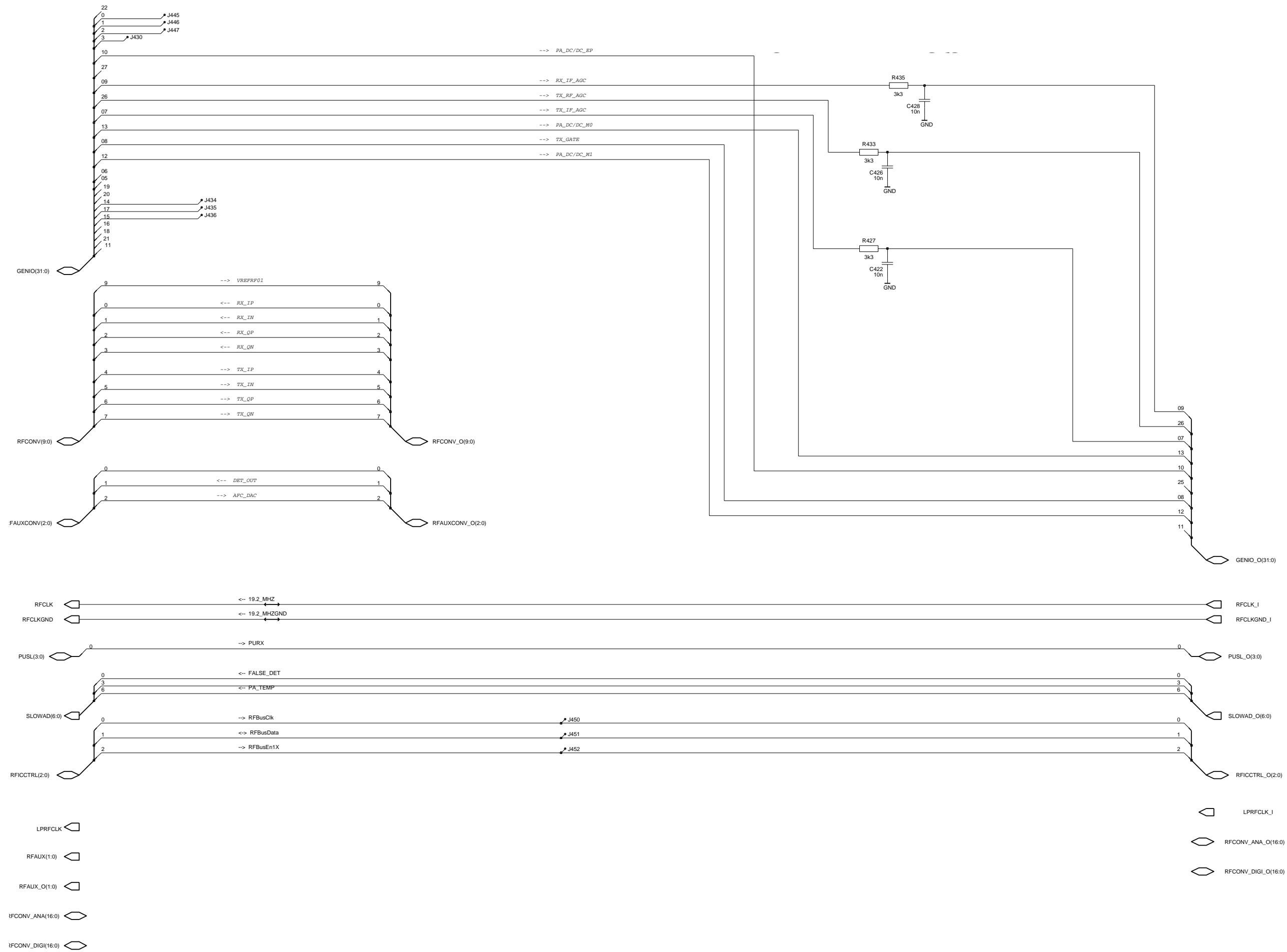

Component Layout — Top

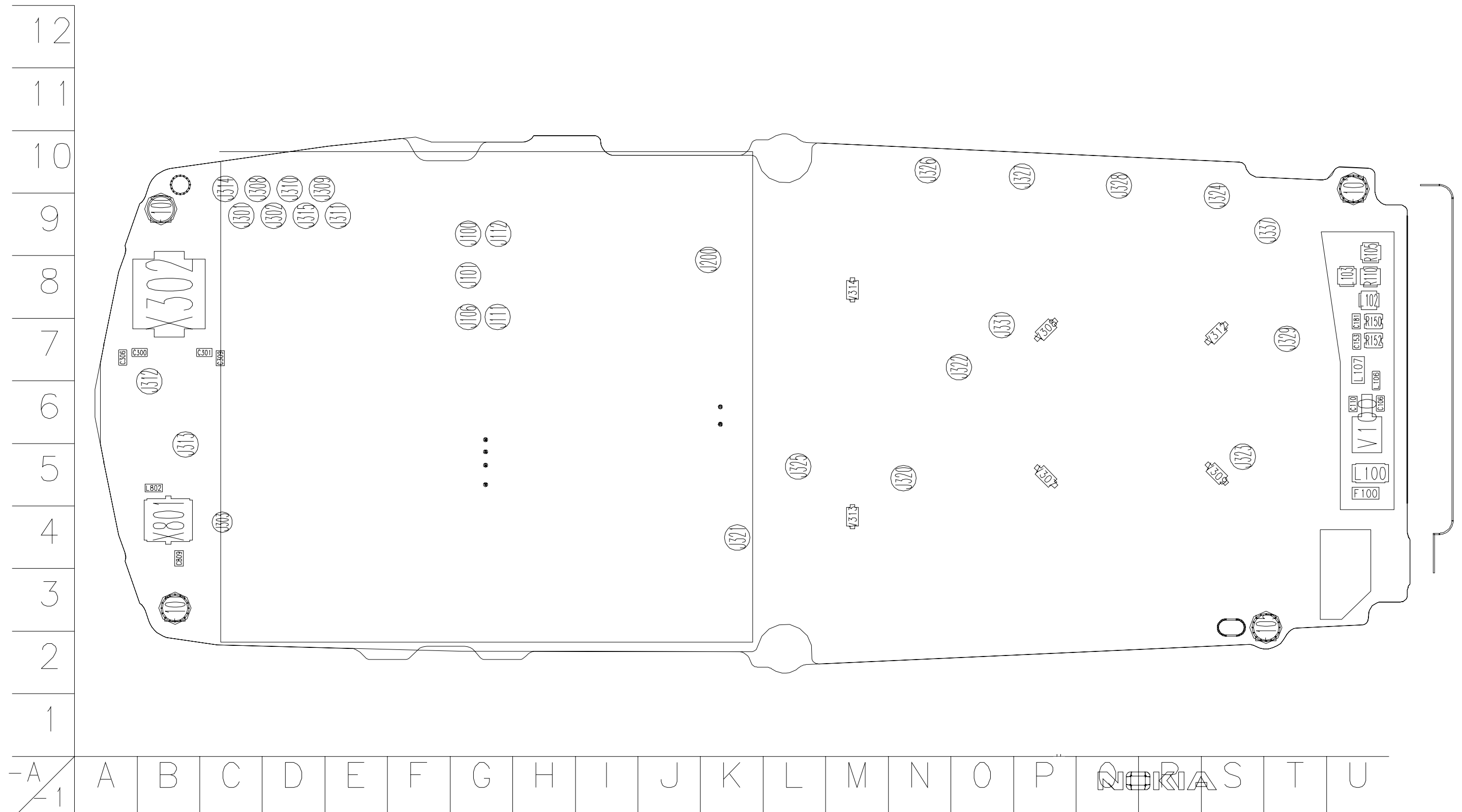

Component Layout — Bottom



Component Values — Top

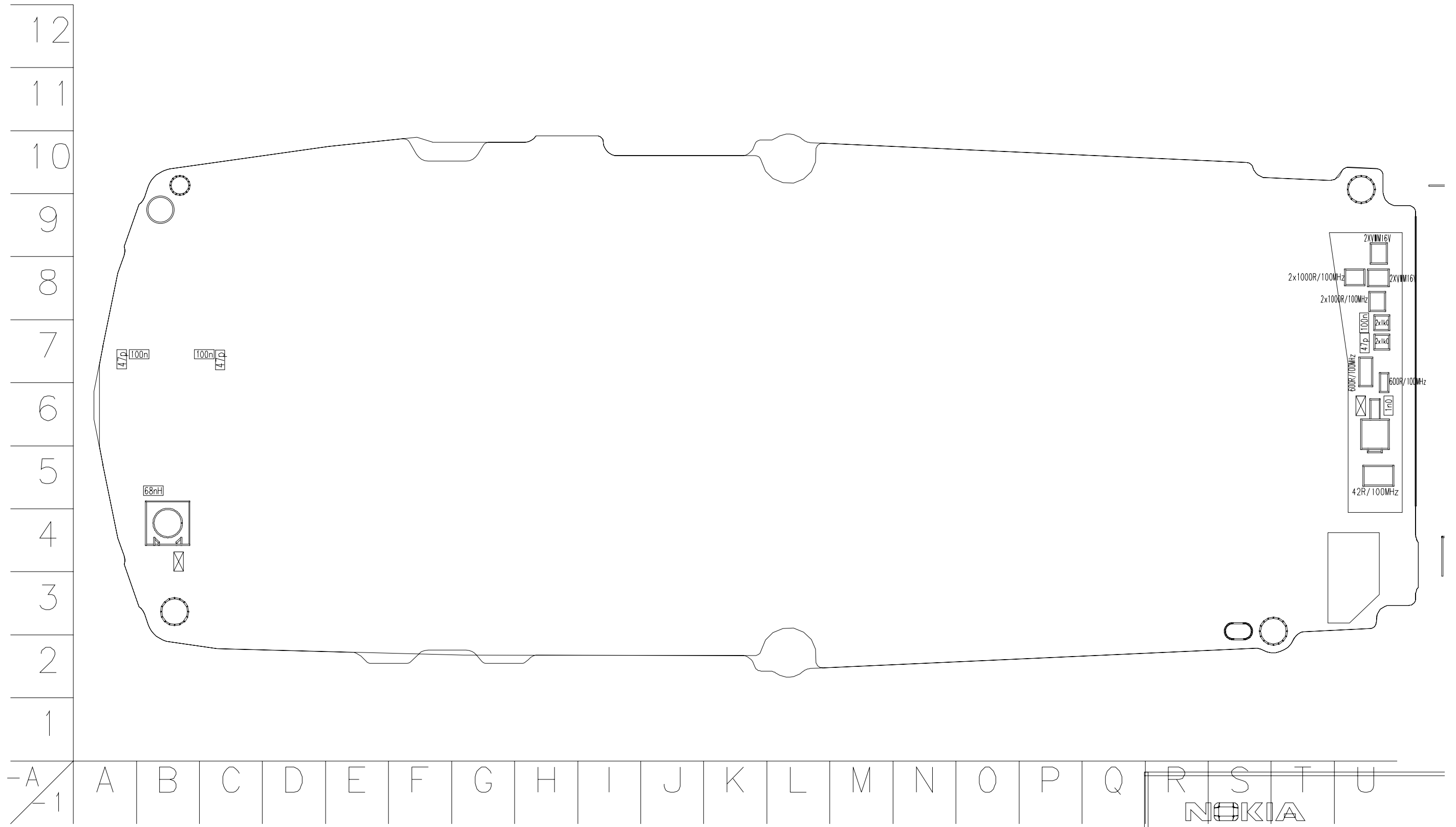

Component Values — Bottom

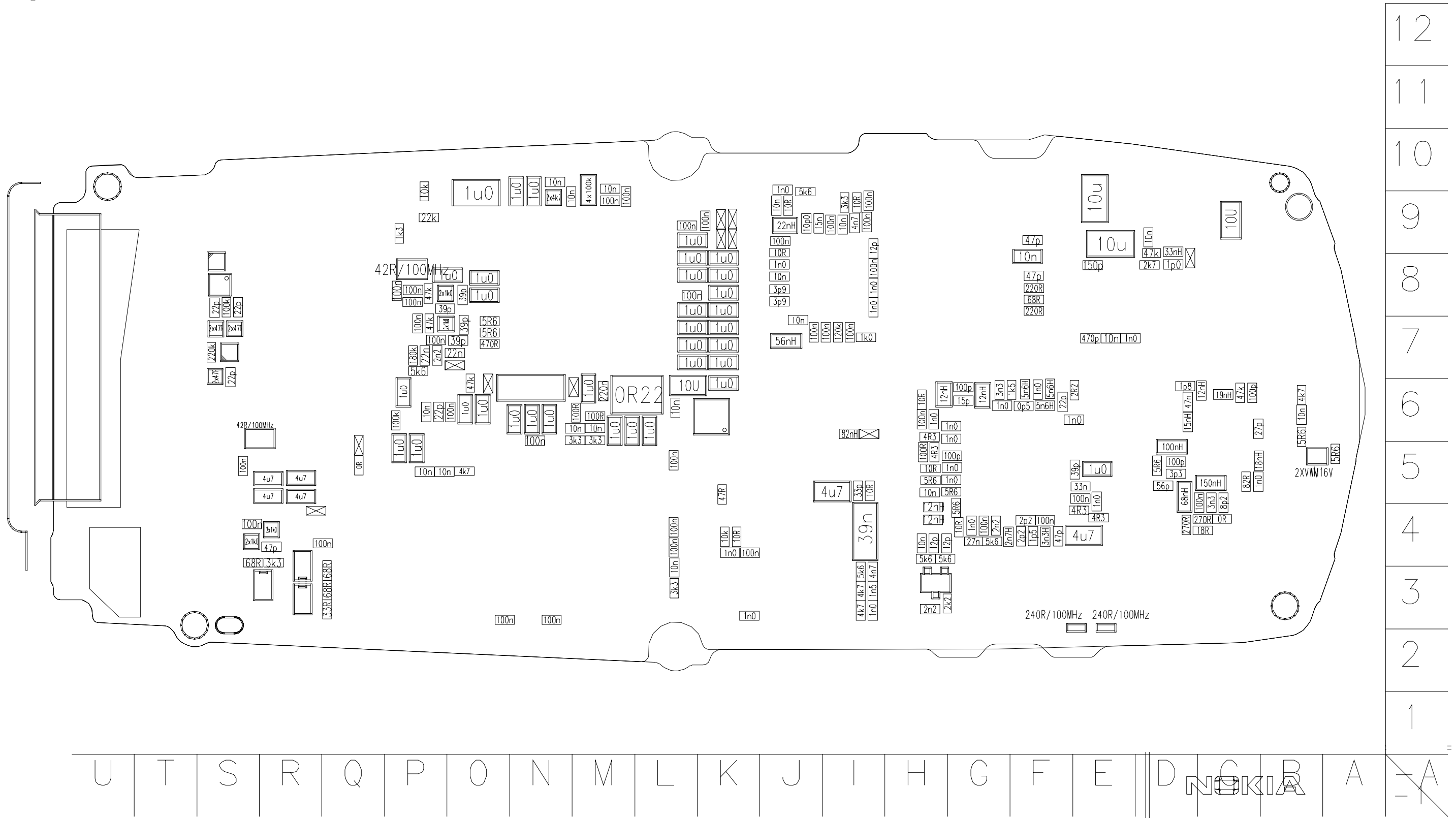

This page intentionally left blank.